

F

E

D

C

B

A



RoHS Compliant

ZONE	SYMBOL	REVISION	APPROVAL	DATE

1

1

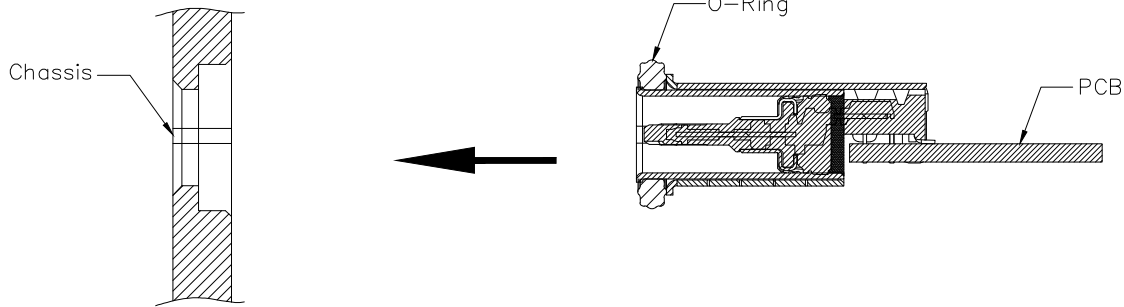

Assembly method

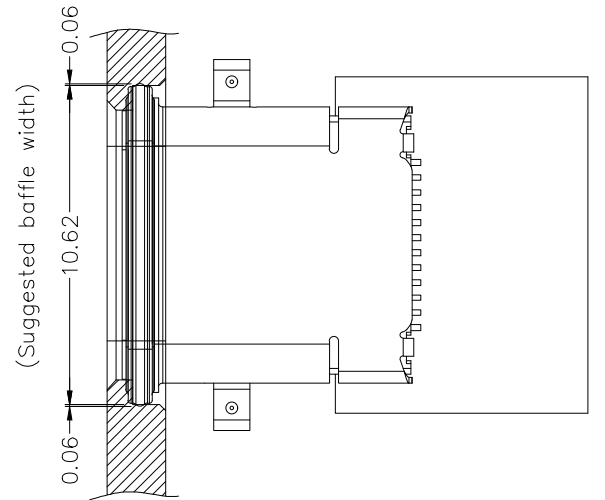

2

2

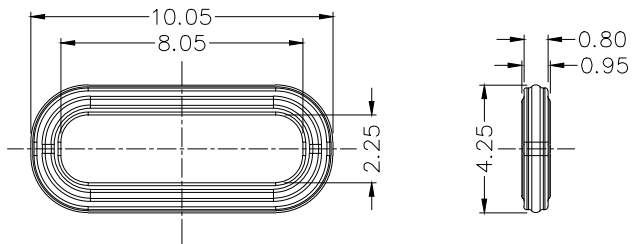

O-ring size (uncompressed)

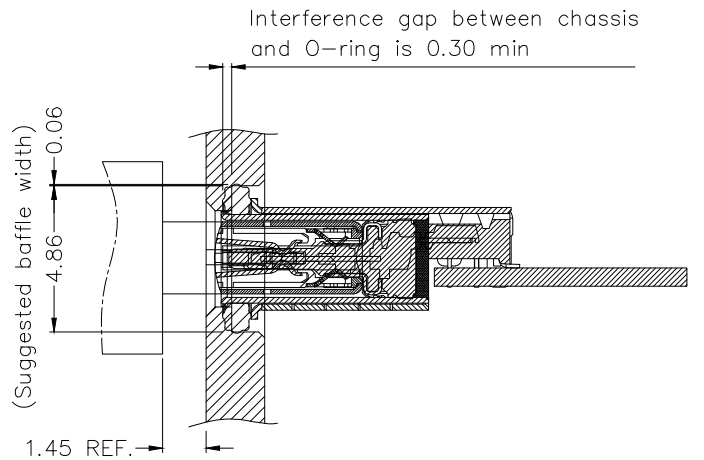

After assembling on chassis

3

3

4

4



LINKPLEX TECHNOLOGY LIMITED

PART NAME	WATERPROOF USB 3.2 TYPE-C (24 PIN) CONNECTOR	TOLERANCE UNLESS	0.0±0.3 0.00±0.2 OTHERWISE SPECIFIED: 0.000±0.1	UNIT:	
PART NO.	LWP-C105D				

DESIGN	H.L.TAN	DATE	18-4-2020	SCALE	4:1
DRAWING	J.Q.ZHOU	DATE	5-1-2024	MATERIAL	
CHECK	T.Y.LI	DATE	5-1-2024	DWG. NO.	TZ\WPC105D-A/2.0
APPROVAL	H.Q.ZHOU	DATE	5-1-2024	SHEET	2/2

F

E

D

C

B

A