



F

E

D

C

B

A



RoHS  
Compliant

ZONE	SYMBOL	REVISION	APPROVAL	DATE

1

1

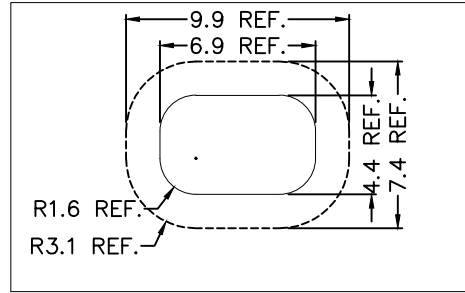

Top View

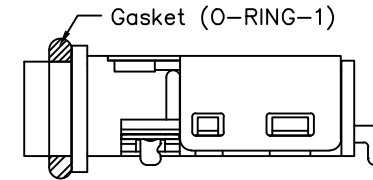
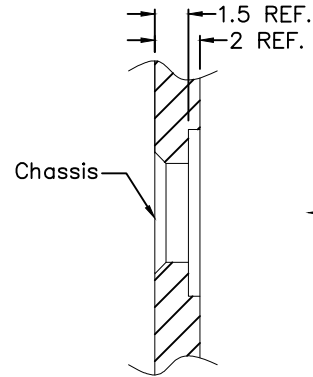

2

2

3

3

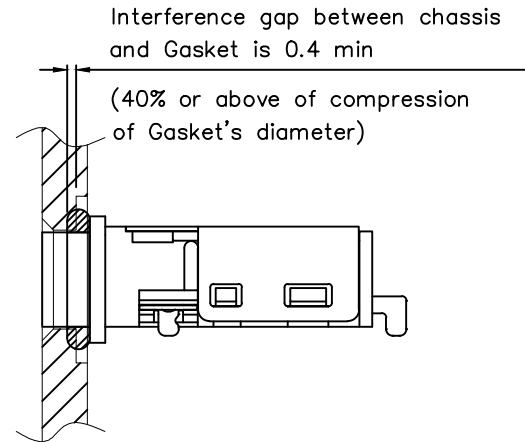
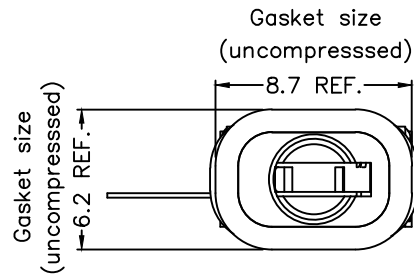

After assembling on chassis

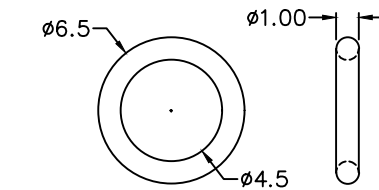

\* Recommended Waterproof Gasket

Gasket Part No.: O-RING-1

4

4



LINKPLEX TECHNOLOGY LIMITED

DESIGN	H.L.TAN	DATE	3-2-2013	SCALE	3:1
DRAWING	Y.J.GUO	DATE	7-7-2024	MATERIAL	
CHECK	T.Y.LI	DATE	7-7-2024	DWG. NO.	TZ\WP3004S-A/3.1
APPROVAL	H.Q.ZHOU	DATE	7-7-2024	SHEET	2/2

PART NAME	WATERPROOF 3.5MM AUDIO JACK	TOLERANCE UNLESS	0.0±0.2	UNIT:	mm
PART NO.	LWP-3004S	OTHERWISE SPECIFIED:	0.00±0.1 0.000±0.05		

F

E

D

C

B

A