

F

E

D

C

B

A

ZONE	SYMBOL	REVISION	APPROVAL	DATE
B4	(A)	MODIFY DESCRIPTION	H.Q.ZHOU	18-11-2023

RoHS
Compliant

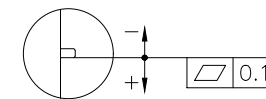
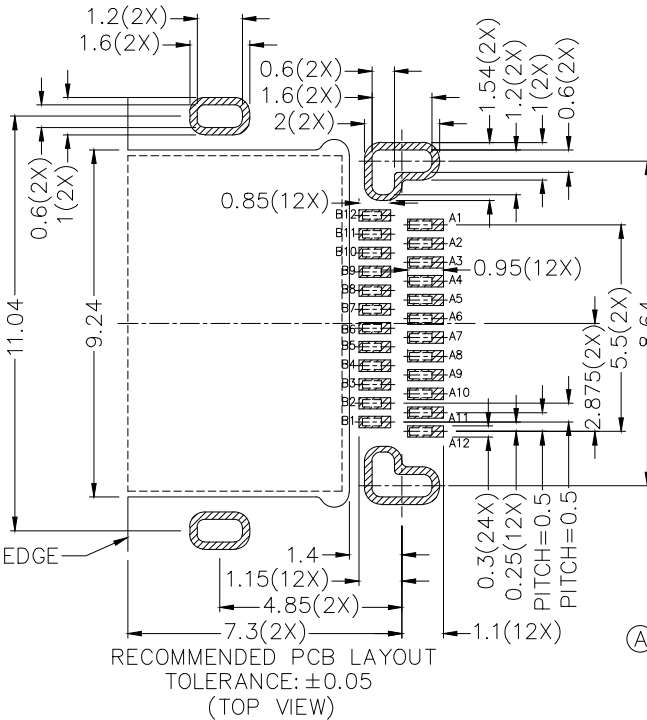
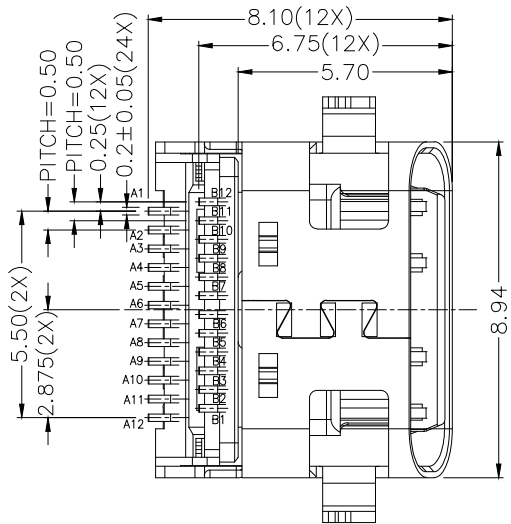
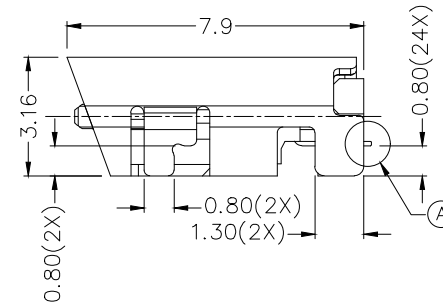
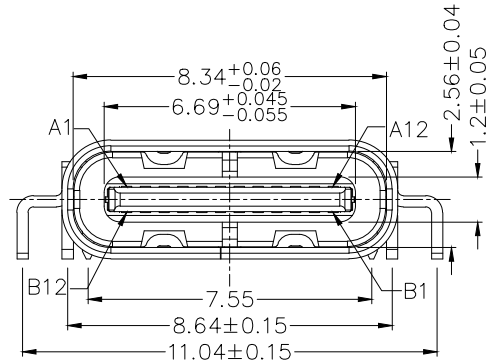
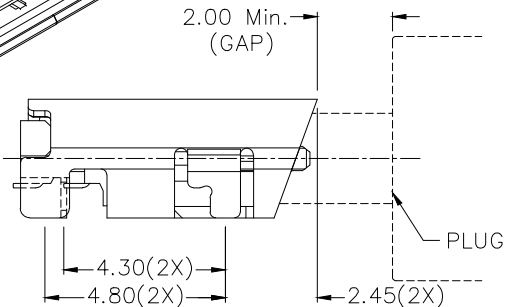
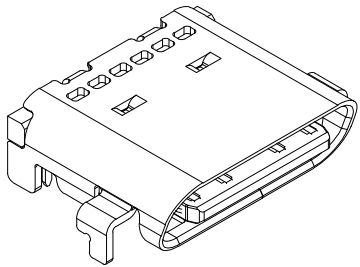

A DETAIL COPLANARITY

PIN ASSIGNMENT (FRONT VIEW)

PIN NO.	A1	A2	A3	A4	A5	A6	A7	A8	A9	A10	A11	A12
	GND	TX1+	TX1-	Vbus	CC1	D+	D-	SBU1	Vbus	RX2-	RX2+	GND
PIN NO.	B12	B11	B10	B9	B8	B7	B6	B5	B4	B3	B2	B1
	GND	RX1+	RX1-	Vbus	SBU2	D-	D+	CC2	Vbus	TX2-	TX2+	GND

DESCRIPTION	MATERIAL	PLATING
CONTACT	COPPER ALLOY	NICKEL PLATED ON ALL AREA, Au 3u" MIN ON CONTACT AREA, GOLD FLASH ON SOLDER AREA
SHELL	STAINLESS STEEL	NICKEL(Ni)
EMI PLATE	STAINLESS STEEL	
MIDDLE PLATE	STAINLESS STEEL	Sn 80u" MIN
INSULATOR	HIGH TEMP. PLASTIC	COLOR: BLACK

LINKPLEX TECHNOLOGY LIMITED

DESIGN	H.L.TAN	DATE	4-3-2016	SCALE	5:1
DRAWING	J.H.ZHOU	DATE	18-11-2023	MATERIAL	
CHECK	T.Y.LI	DATE	18-11-2023	DWG. NO.	TZ\UBC130D-A/1.1
APPROVAL	H.Q.ZHOU	DATE	18-11-2023	SHEET	1/1

PART NAME: USB 3.2 TYPE-C (24PIN) CONNECTOR
PART NO.: LUB-C130D

TOLERANCE UNLESS OTHERWISE SPECIFIED:
0.0±0.3
0.00±0.25
0.000±0.1

UNIT: mm

F

E

D

C

B

A