

F

E

D

C

B

A

ZONE	SYMBOL	REVISION	APPROVAL	DATE

**RoHS**  
Compliant

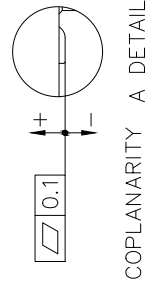
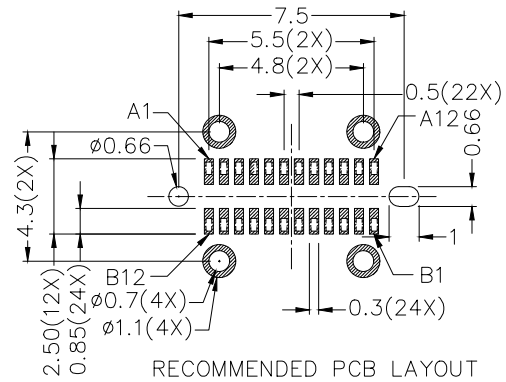
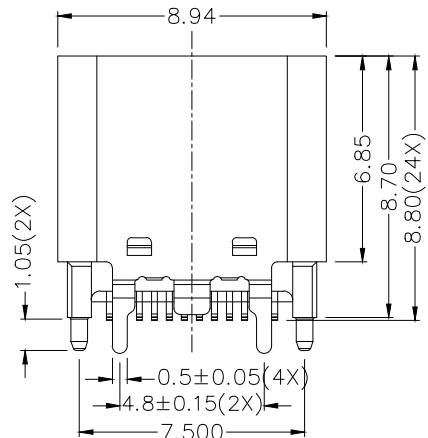
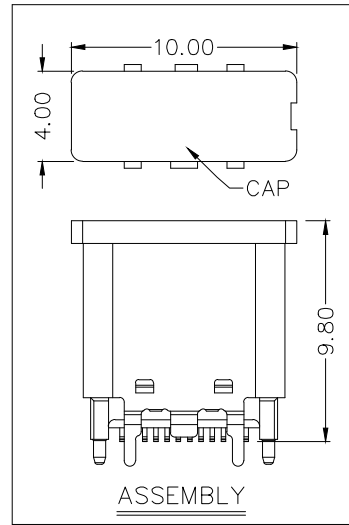
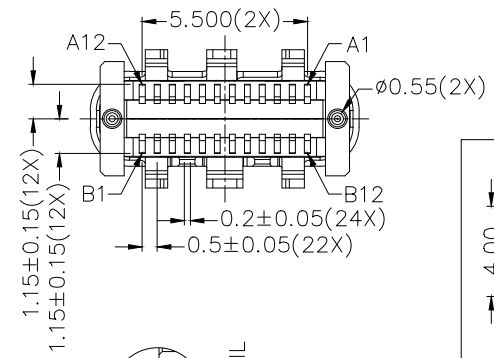
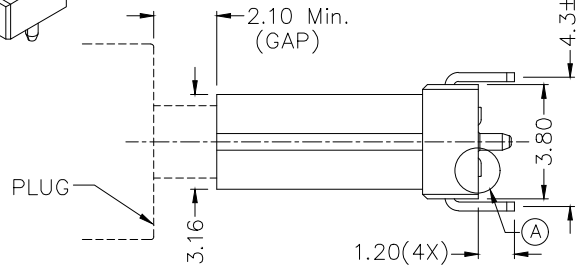
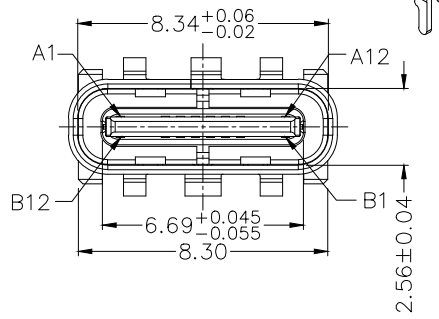
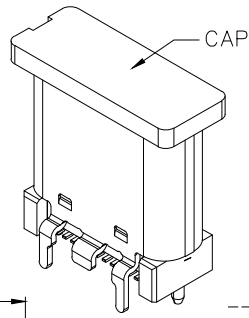
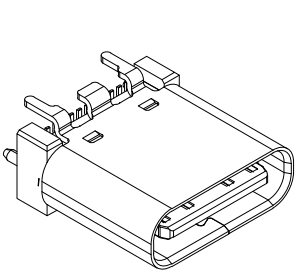

PIN ASSIGNMENT (FRONT VIEW)

PIN NO.	A1	A2	A3	A4	A5	A6	A7	A8	A9	A10	A11	A12
	GND	TX1+	TX1-	Vbus	CC1	D+	D-	SBU1	Vbus	RX2-	RX2+	GND
PIN NO.	B12	B11	B10	B9	B8	B7	B6	B5	B4	B3	B2	B1
	GND	RX1+	RX1-	Vbus	SBU2	D-	D+	CC2	Vbus	TX2-	TX2+	GND

RECOMMENDED PCB LAYOUT  
TOLERANCE: ±0.05  
(TOP VIEW)

DESCRIPTION	MATERIAL	PLATING
CONTACT	COPPER ALLOY	NICKEL PLATED ON ALL AREA, Au 3u" MIN ON CONTACT AREA, TIN PLATED ON SOLDER AREA
SHELL	STAINLESS STEEL	NICKEL(Ni)
EMI PLATE	STAINLESS STEEL	NICKEL(Ni)
MIDDLE PLATE	STAINLESS STEEL	
INSULATOR	HIGH TEMP. PLASTIC	COLOR: BLACK
CAP	HIGH TEMP. PLASTIC	COLOR: BLACK

**LINKPLEX TECHNOLOGY LIMITED**

DESIGN	H.L.TAN	DATE	12-8-2023	SCALE	4:1
DRAWING	J.Q.ZHOU	DATE	11-11-2023	MATERIAL	
CHECK	T.Y.LI	DATE	11-11-2023	DWG. NO.	TZ\UBC125D-A/1.0
APPROVAL	H.Q.ZHOU	DATE	11-11-2023	SHEET	1/1

PART NAME	USB 3.2 TYPE-C (24PIN) CONNECTOR	TOLERANCE UNLESS	0.0±0.3	UNIT:	mm
PART NO.	LUB-C125D	OTHERWISE SPECIFIED:	0.00±0.25 0.000±0.1		

F

E

D

C

B

A