

F

E

D

C

B

A

ZONE	SYMBOL	REVISION	APPROVAL	DATE
		CHANGE PRODUCT NUMBER	H.Q.ZHOU	17-9-2023

RoHS
Compliant

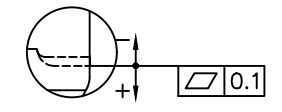
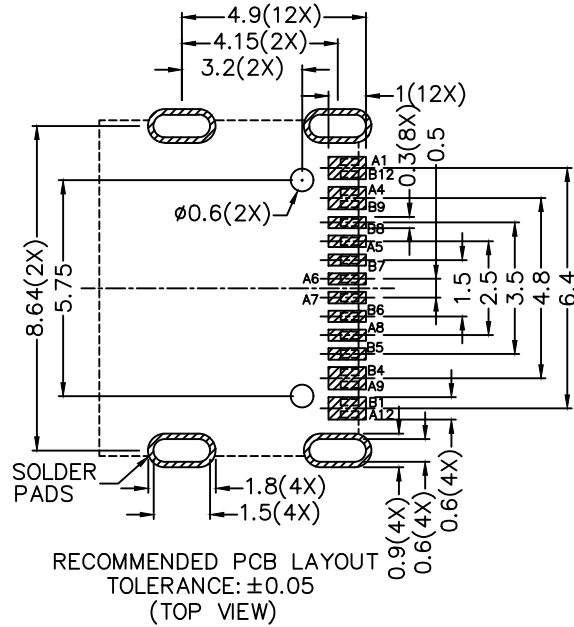
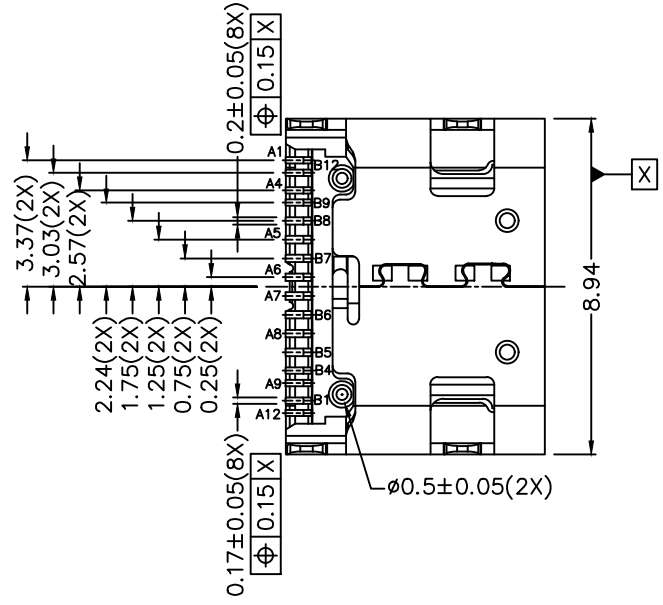
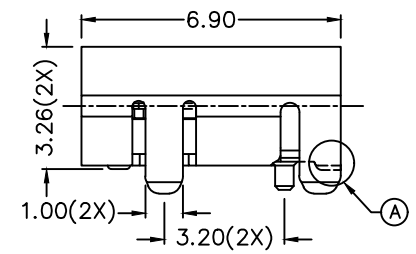
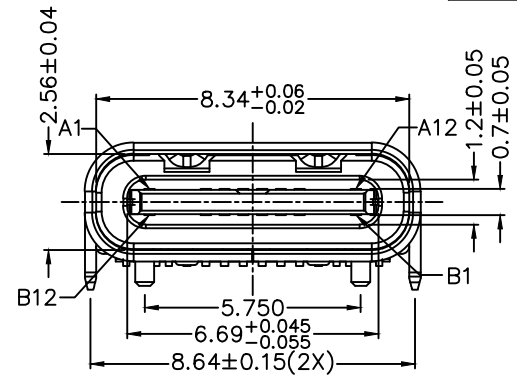
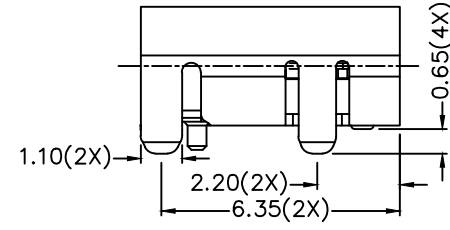
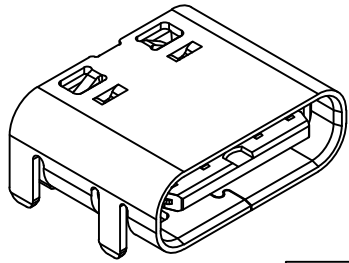

A DETAIL COPLANARITY

PIN ASSIGNMENT (FRONT VIEW)

PIN NO. A1	A4	A5	A6	A7	A8	A9	A12
GND	Vbus	CC1	D+	D-	SBU1	Vbus	GND
PIN NO. B12	B9	B8	B7	B6	B5	B4	B1
GND	Vbus	SBU2	D-	D+	CC2	Vbus	GND

RECOMMENDED PCB LAYOUT
TOLERANCE: ±0.05
(TOP VIEW)

DESCRIPTION	MATERIAL	PLATING
TERMINAL-A	COPPER ALLOY	NICKEL PLATED ON ALL AREA, Au 1u" MIN ON CONTACT AND SOLDER AREA
TERMINAL-B	COPPER ALLOY	NICKEL PLATED ON ALL AREA, Au 1u" MIN ON CONTACT AND SOLDER AREA
SHELL	STAINLESS STEEL	NICKEL(Ni)
MIDDLE PLATE	STAINLESS STEEL	
INSULATOR	HIGH TEMP. PLASTIC	COLOR: BLACK

LINKPLEX TECHNOLOGY LIMITED

DESIGN	H.L.TAN	DATE	22-7-2017	SCALE	5:1
DRAWING	J.Q.ZHOU	DATE	17-9-2023	MATERIAL	
CHECK	T.Y.LI	DATE	17-9-2023	DWG. NO.	TZ\UBC113D-A/1.1
APPROVAL	H.Q.ZHOU	DATE	17-9-2023	SHEET	1/1

PART NAME	USB 2.0 TYPE-C (16PIN) CONNECTOR	TOLERANCE UNLESS	0.0±0.3	UNIT:	mm
PART NO.	LUB-C113D	OTHERWISE SPECIFIED:	0.00±0.2 0.000±0.1		

F

E

D

C

B

A