

F

E

D

C

B

A

RoHS Compliant

ZONE	SYMBOL	REVISION	APPROVAL	DATE
		CHANGE PRODUCT NUMBER	H.Q.ZHOU	17-9-2023

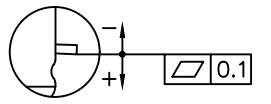
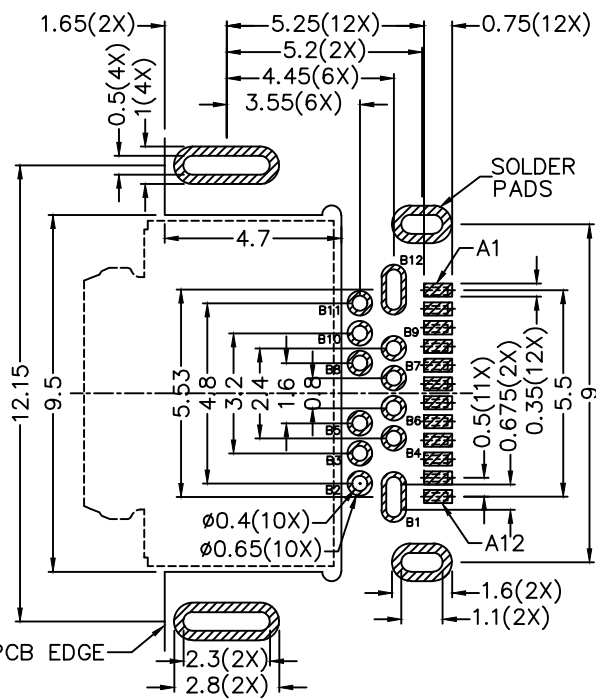
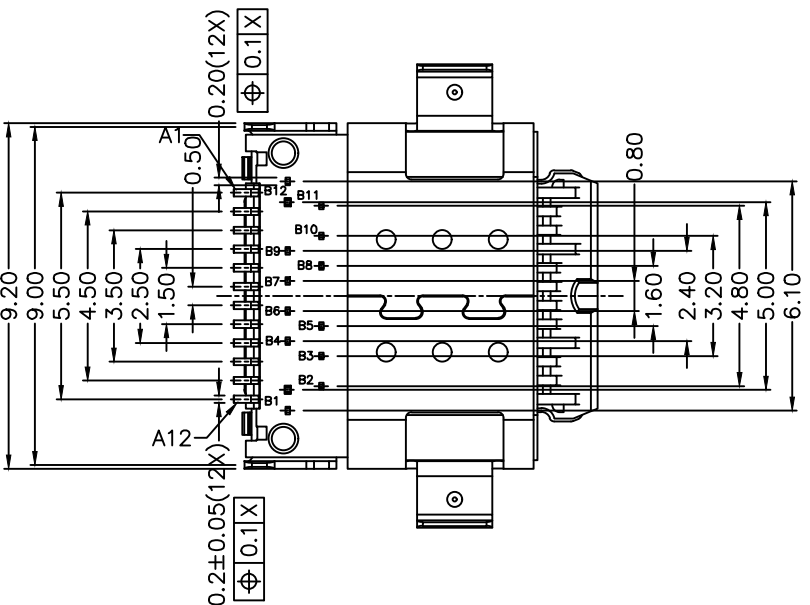
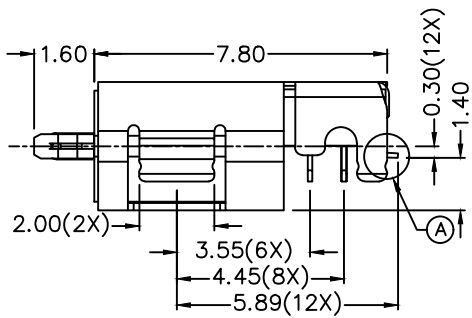
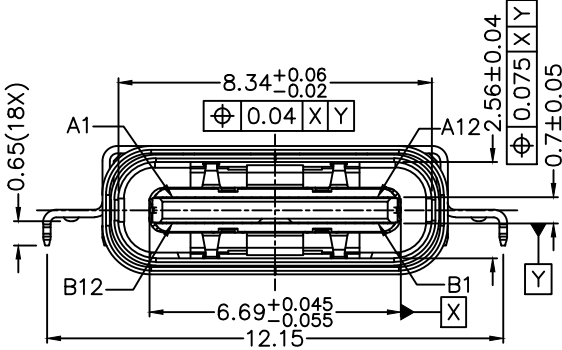
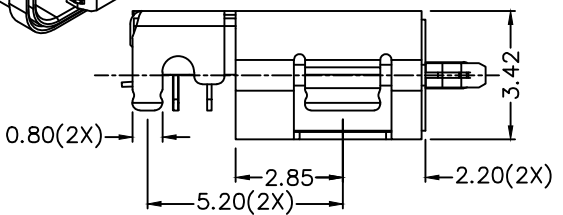
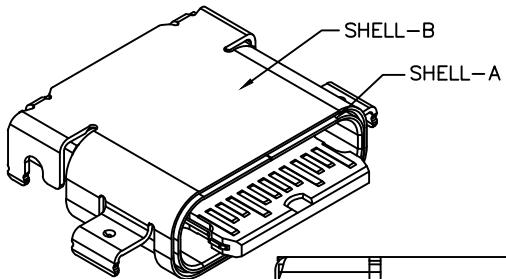

A DETAIL COPLANARITY

PIN ASSIGNMENT (FRONT VIEW)

PIN NO.	A1	A2	A3	A4	A5	A6	A7	A8	A9	A10	A11	A12
	GND	TX1+	TX1-	Vbus	CC1	D+	D-	SBU1	Vbus	RX2-	RX2+	GND
PIN NO.	B12	B11	B10	B9	B8	B7	B6	B5	B4	B3	B2	B1
	GND	RX1+	RX1-	Vbus	SBU2	D-	D+	CC2	Vbus	TX2-	TX2+	GND

RECOMMENDED PCB LAYOUT TOLERANCE: ±0.05 (TOP VIEW)

DESCRIPTION	MATERIAL	PLATING
TERMINAL-A	COPPER ALLOY	NICKEL PLATED ON ALL AREA, Au 15u" MIN ON CONTACT AREA, Au 1u" MIN ON SOLDER AREA.
TERMINAL-B	COPPER ALLOY	NICKEL PLATED ON ALL AREA, Au 15u" MIN ON CONTACT AREA, Au 1u" MIN ON SOLDER AREA.
SHELL-A	STAINLESS STEEL	NICKEL(Ni)
SHELL-B	STAINLESS STEEL	NICKEL(Ni)
INNER GROUND COVER SHELL	STAINLESS STEEL	NICKEL(Ni)
MIDDLE PLATE	STAINLESS STEEL	
INSULATOR	HIGH TEMP. PLASTIC	COLOR: BLACK

LINKPLEX TECHNOLOGY LIMITED

DESIGN	H.L.TAN	DATE	12-8-2020	SCALE	5:1
DRAWING	J.Q.ZHOU	DATE	17-9-2023	MATERIAL	
CHECK	T.Y.LI	DATE	17-9-2023	DWG. NO.	TZ\UBC112D-A/1.1
APPROVAL	H.Q.ZHOU	DATE	17-9-2023	SHEET	1/1

PART NAME	USB 3.2 TYPE-C (24PIN) CONNECTOR	TOLERANCE UNLESS	0.0±0.3	UNIT:	mm
PART NO.	LUB-C112D	OTHERWISE SPECIFIED:	0.00±0.2 0.000±0.1		

F

E

D

C

B

A