

F

E

D

C

B

A

RoHS  
Compliant

ZONE	SYMBOL	REVISION	APPROVAL	DATE

## NOTES:

- Electrical
  - .Rated Current & Voltage: DC 12V; 1.0A
  - .Contact Resistance: 100 mohm maximum at Working Height(Quiescence)
- Mechanical
  - .Full store: 1.00 mm
  - .Spring Force: 30gf±7gf at Working Height
  - .Durability:10,000 cycles(minimum)
- Environmental
  - .Operating Temperature: -40°C~+85°C
  - .Humidity Range: 10%RH~90%RH
- When the current is greater than 1A then need to increase the time delay circuit(3 second)
- To avoid arcing issue, The adaptor start to power supply after connector mated fully.
- To ensure the best usage,please operate it based on the working height.

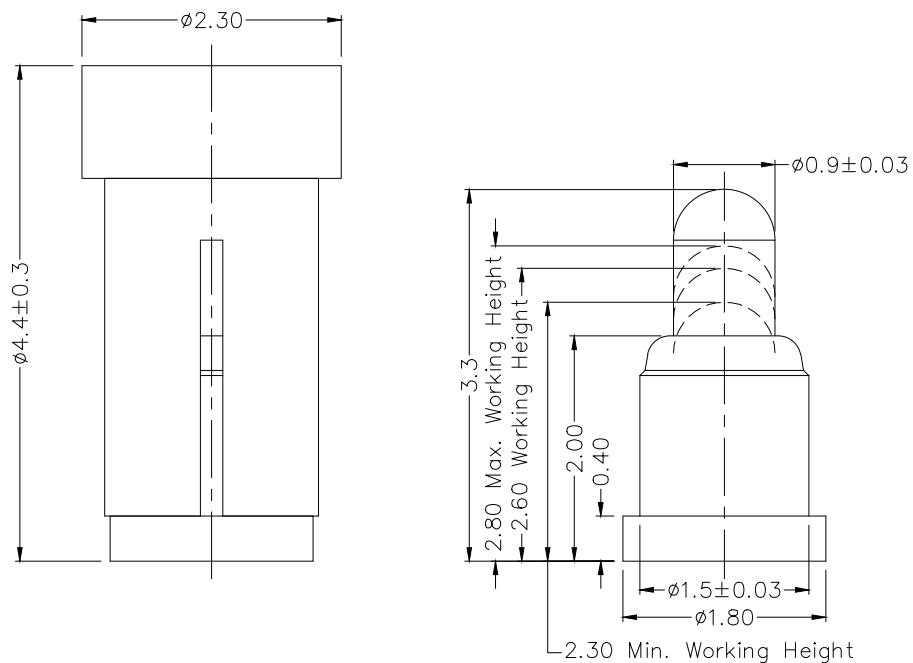

PART NAME	MATERIAL	PLATED SURFACE
PLUNGER	BRASS	AU 1U" MIN. OVER 50~120U" NI
BARREL	BRASS	AU 1U" MIN. OVER 50~120U" NI
SPRING	SUS304	AU 1U" MIN. OVER NI
CAP	HIGH TEMP.PLASTIC; UL94 V-0 COLOR BLACK	



LINKPLEX TECHNOLOGY LIMITED

PART NAME	POGO PIN	TOLERANCE UNLESS	0.±0.15	UNIT:	mm
PART NO.	LPG-015	OTHERWISE SPECIFIED:	0.0±0.1 0.00±0.05		

DESIGN	H.L.TAN	DATE	7-1-2021	SCALE	20:1
DRAWING	N.X.LIU	DATE	1-8-2022	MATERIAL	
CHECK	T.Y.LI	DATE	1-8-2022	DWG. NO.	TZ\PG015/1.0
APPROVAL		DATE	1-8-2022	SHEET	1/1

F

E

D

C

B

A