

F

E

D

C

B

A

RoHS  
Compliant

ZONE	SYMBOL	REVISION	APPROVAL	DATE

## NOTES:

- Electrical  
.Rated Current & Voltage: DC 12V; 1.0A Max.  
.Contact Resistance: 50 mohm maximum  
at Working Height(Quiescence)
- Mechanical  
.Full store: 0.90 mm  
.Working Store: 0.80 mm  
.Spring Force: 60gf±15gf at Working Height  
.Durability:10,000 cycles(minimum)
- Environmental  
.Operating Temperature: -30°C~+85°C  
.Humidity Range: 10%RH~90%RH  
.Salt Spray: 48 Hours
- When the current is greater than 1A then need to increase the time delay circuit(3 second)
- To avoid arcing issue, The adaptor start to power supply after connector mated fully.
- To ensure the best usage,please operate it based on the working height.

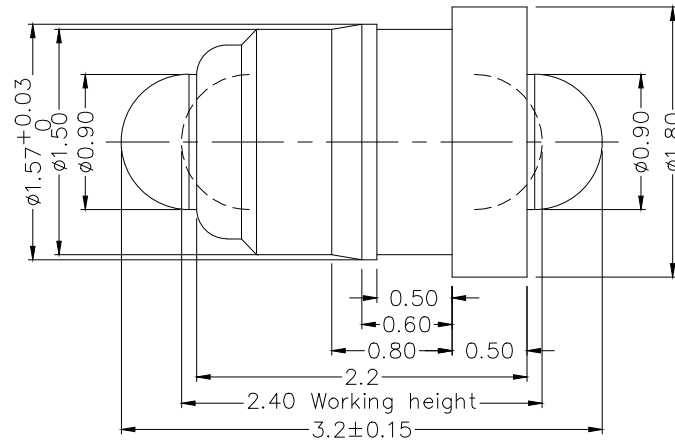

PART NAME	MATERIAL	PLATED SURFACE
PLUNGER	BRASS	AU 1U" MIN OVER 50~120U" NI
BARREL	BRASS	AU 1U" MIN OVER 50~120U" NI
SPRING	SUS	



LINKPLEX TECHNOLOGY LIMITED

PART NAME	POGO PIN	TOLERANCE UNLESS	0.±0.15	UNIT:	mm
PART NO.	LPG-014	OTHERWISE SPECIFIED:	0.00±0.05		

DESIGN	H.L.TAN	DATE	7-1-2021	SCALE	20:1
DRAWING	N.X.LIU	DATE	1-8-2022	MATERIAL	
CHECK	T.Y.LI	DATE	1-8-2022	DWG. NO.	TZ\PG014/1.0
APPROVAL	<i>[Signature]</i>	DATE	1-8-2022	SHEET	1/1

F

E

D

C

B

A