

F

E

D

C

B

A

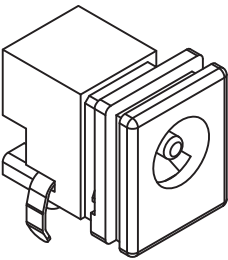

RoHS
Compliant

| ZONE | SYMBOL | REVISION | APPROVAL | DATE |
|------|--------|---------------------------|-----------|-----------|
| | | ADJUST THE RECOMMENDED DC | J.X.KUANG | 8-10-2019 |
| | | MATING PLUG | | |

1

1

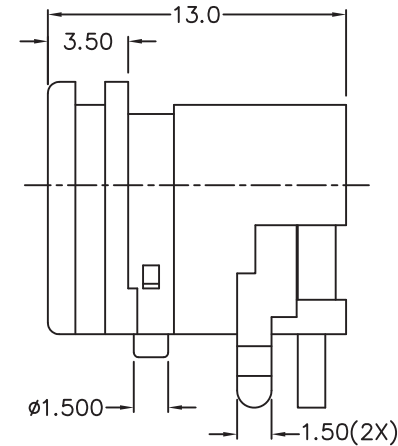
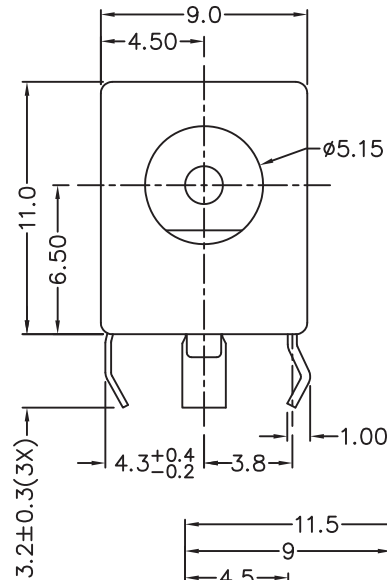
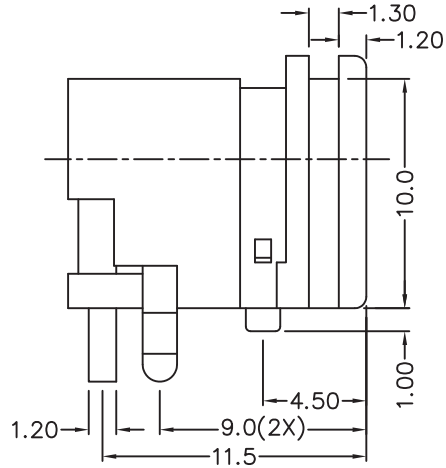
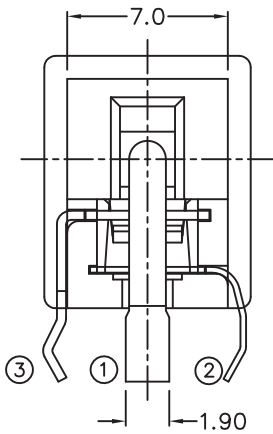

2

2

3

3

| | |
|------------|----------|
| MODEL NO. | LDC-024H |
| SCHEMATIC | 1, 2, 3 |
| CENTRE PIN | ø1.650mm |

*** MATERIAL**

- TERMINAL 1 : COPPER
- TERMINAL 2 : COPPER ALLOY
- TERMINAL 3 : BRASS
- HOUSING : THERMOPLASTIC

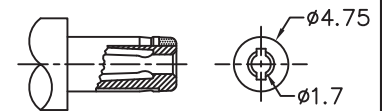
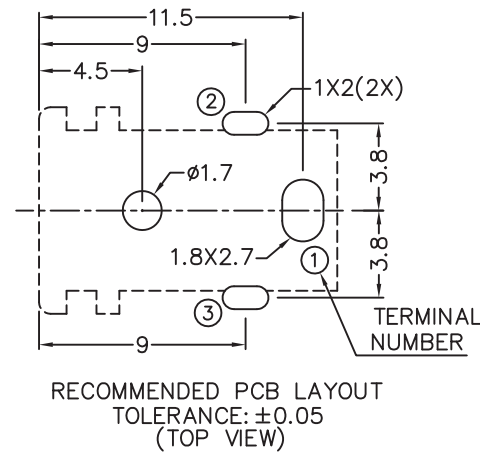

4

4

LINKPLEX TECHNOLOGY LIMITED

| | | | | | |
|----------|-----------|------|------------|----------|-----------------|
| DESIGN | J.X.KUANG | DATE | 10-10-2003 | SCALE | 3:1 |
| DRAWING | H.Q.ZHOU | DATE | 8-10-2019 | MATERIAL | * |
| CHECK | H.L.TAN | DATE | 8-10-2019 | DWG. NO. | TZ\DC024H-B/1.1 |
| APPROVAL | | DATE | 16-10-2019 | SHEET | |

| | | | | | |
|-----------|------------------------------|----------------------|-----------------------|-------|--|
| PART NAME | HIGH CURRENT DC POWER SOCKET | TOLERANCE UNLESS | 0.0±0.5 | UNIT: | |
| PART NO. | LDC-024H | OTHERWISE SPECIFIED: | 0.00±0.3 0.000±0.2 | mm | |

F

E

D

C

B

A